

# ***i-max*** **PRO**

**MAKES LIFE EASIER**

**NEW GENERATION PANORAMIC UNITS  
2D, 3D, CEPH VERSION**

20 YEARS OF INNOVATION

Owandy  
RADIOLOGY

and **optimisation of manufacturing resources**  
with a highly specific goal:

respect for  
**the environment**



## MANUFACTURE

With product weight reduced from **210kg to 62kg**, fewer material resources are needed for Owandy's machines.



## TRANSPORT

A lighter product **significantly lowers CO<sup>2</sup> emissions.**



## RECYCLING

**Less waste to be recycled** at the end-of-life stage.

## MODERN TECHNOLOGY CAN BE COMPATIBLE WITH RESPECT FOR THE ENVIRONMENT

Because material resources are not infinite, Owandy Radiology has spent the last 20 years **innovating and optimising** its products in order to **reduce the quantity of materials required to produce them.**

## LIFE CYCLE OPTIMISATION

As part of its **sustainable development** strategy, Owandy Radiology has **considerably reduced the carbon footprint of its products.**



# UNPARALLELED IMAGE QUALITY



---

## LATEST GENERATION CMOS SENSOR

Exceptional image quality while reducing X-Ray doses to protect your patients.

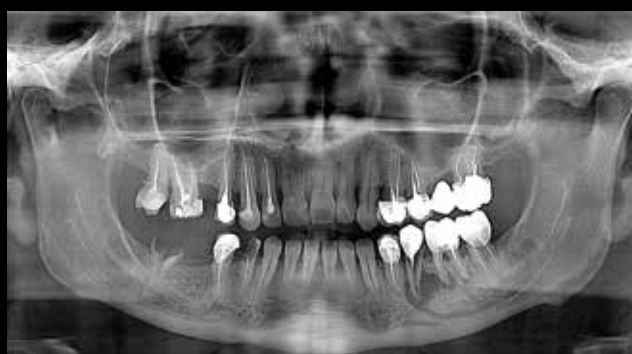

## AutoMAR BY OWANDY (Automatic Metal Artefact Reduction)

Reduced artefact radiation thanks to our new algorithm.

Without AutoMar

With AutoMAR



# COMPREHENSIVE RANGE 2D, 3D, CEPH VERSIONS

## ULTRA-COMPACT DESIGN

The I-Max Pro range has been designed to be installed in any type of surgery configuration quickly and efficiently.

## “FACE TO FACE” POSITIONING

Being in front of the patient creates optimum conditions for correct positioning.

## BEST RATIO PERFORMANCE INVESTMENT

A range designed to deliver total satisfaction.

## SCALABLE

Upgrade to a superior version depending on your requirements.

## SOFTWARE COMPATIBILITY

Products in the I-Max PRO range are compatible with all major management software packages on the market.

I-MAX PRO



I-MAX 3D PRO



I-MAX CEPH PRO



I-MAX 3D CEPH PRO



# **i-max** *PRO*

- Latest generation CMOS sensor
- Compact design (< 1m<sup>2</sup>)
- Wall-mounted concept, Ø floor footprint
- “Face to face” positioning
- 24 2D programmes

## I-MAX PRO PANORAMIC



# *i-max 3D* PRO

- High definition images: 72µm
- Compact design (< 1m<sup>2</sup>)
- Wall-mounted concept,  
Ø floor footprint
- “Face to face” positioning
- 18 3D programmes
- FOV from 12x10 to 5x5cm



I-MAX 3D PRO CONE BEAM





## 3D CONE BEAM MULTI-FOV (Field Of View)\*



**12 x 10 cm**  
Full dentition with condyles  
(optional)



**9 x 9 cm**  
Full dentition



**9 x 5 cm**  
Full arch



**5 x 5 cm**  
Sectoral volume

\* Volume



### MULTIPURPOSE EQUIPMENT: 4 IN 1

Panoramic, 3D and  
cephalometric images and  
3D object scanner (impression  
trays, plaster models).

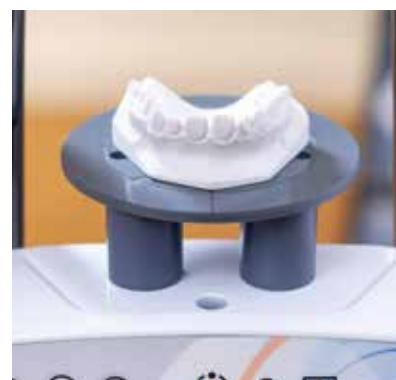

# QUICKVISION 3D SOFTWARE

- Creation of surgical guides
- AI\* automatic matching of .DICOM and .STL files
- CAD/CAM-ready (.STL file sharing)
- Management of entire digital workflow

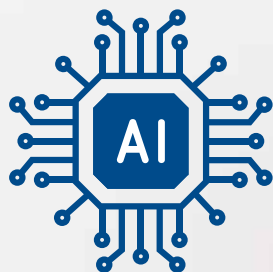

## GUIDED SURGERY: ACCURACY AND SAFETY

**QuickVision 3D** is a comprehensive and powerful software package that can be used to simulate implant placement on 2D and 3D models. Option to **import .STL files** from your laboratory or your dental impression camera.

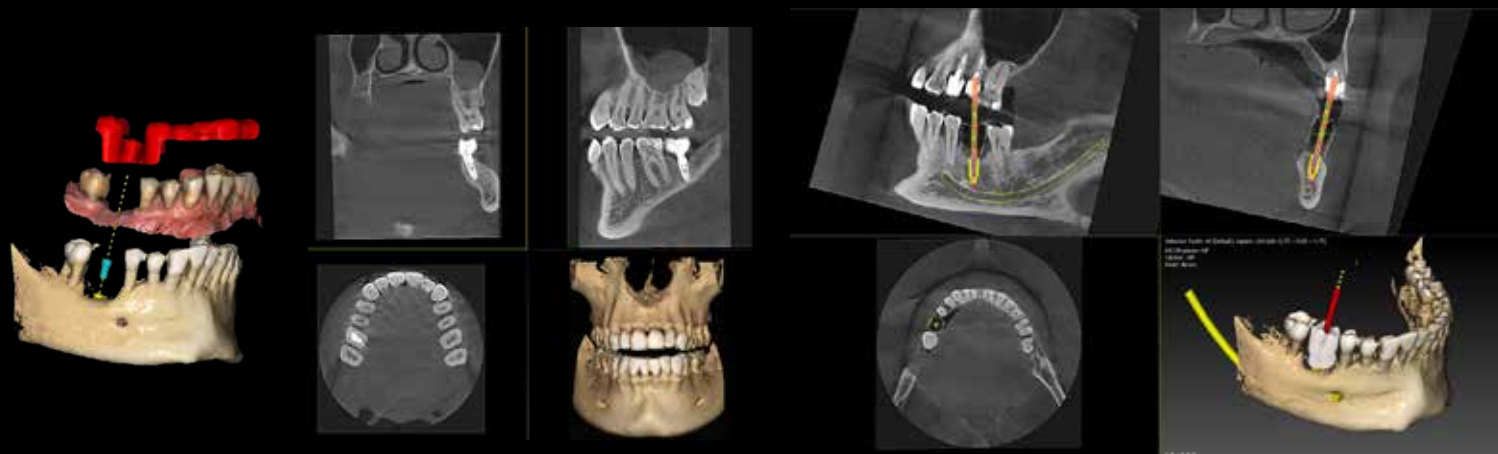

# OWANDY ACADEMY

## CUSTOMISED TRAINING

Owandy also offers a remote training service. Our experts are on hand to help, providing support for any request, from the most basic to the most complex (full arch guided surgery).

# ***i-max* CEPH *PRO***

- Ultra-compact: 185cm wide
- “Face to face” positioning
- Low dose
- 9 CEPH programmes
- 200 types of exams with Ceph Analysis

4 IN 1 **I-MAX CEPH 3D PRO**



Lateral view  
18 x 24 cm

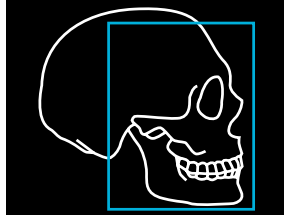

Lateral view 18 x 18 cm  
(reduced dose)

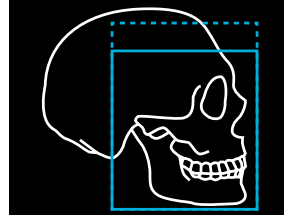

Frontal view  
24 x 24 cm



Lateral view  
24 x 24 cm

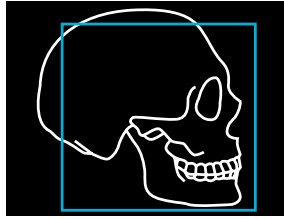

Lateral view 24 x 18 cm  
(reduced dose)

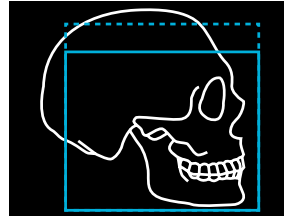

Frontal view 24 x 18 cm  
(reduced dose)



Full skull lateral view  
30 x 24 cm

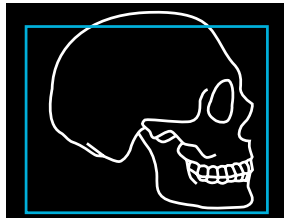

Full skull lateral view  
30 x 18 cm (reduced dose)

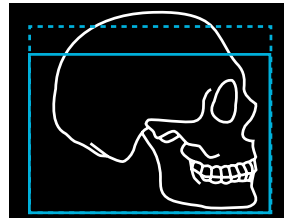

Carpus  
18 x 24 cm

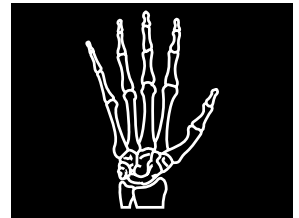

### CEPH ANALYSIS

Cephalometric analysis software, incorporating Artificial Intelligence for automatic plots. Over 200 exam types available.

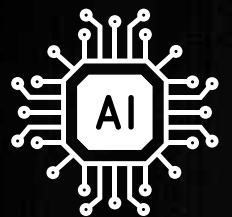
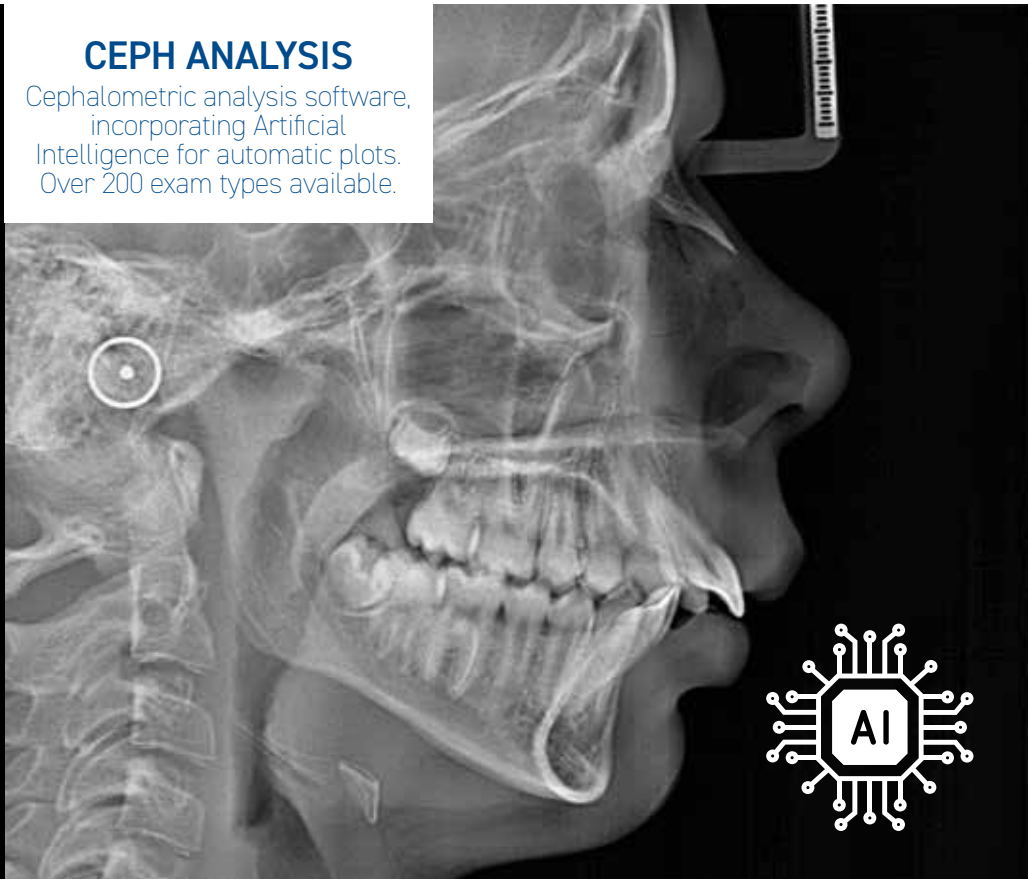
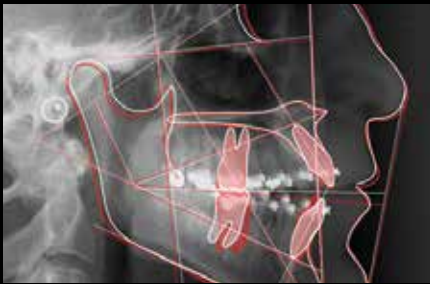
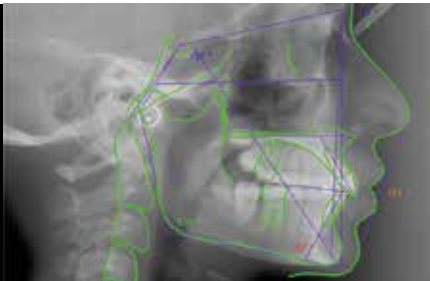

\*Optional

# TECHNICAL FEATURES

## I-MAX PRO I-MAX 3D PRO

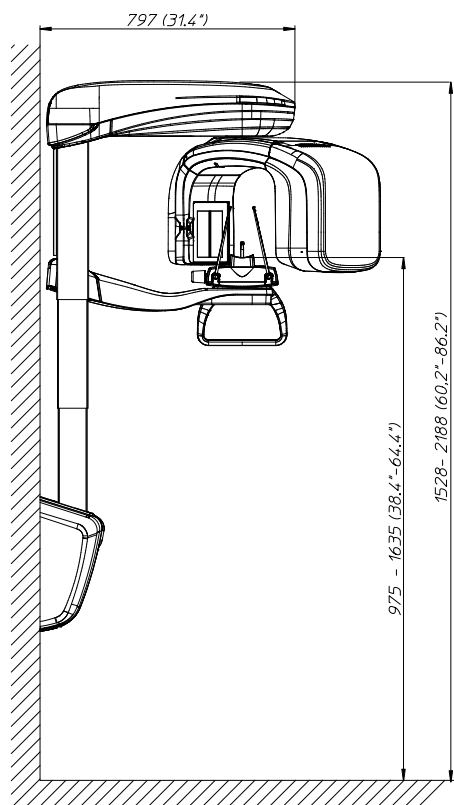
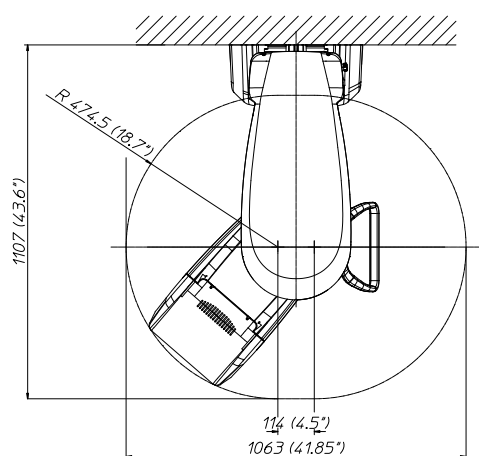

## I-MAX CEPH PRO I-MAX 3D CEPH PRO

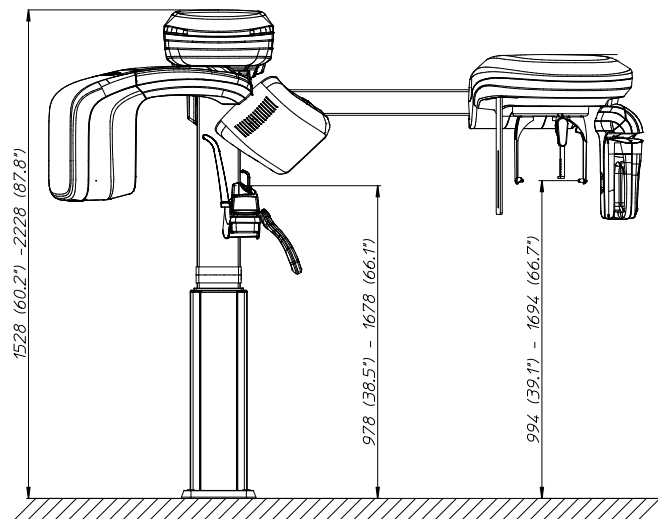
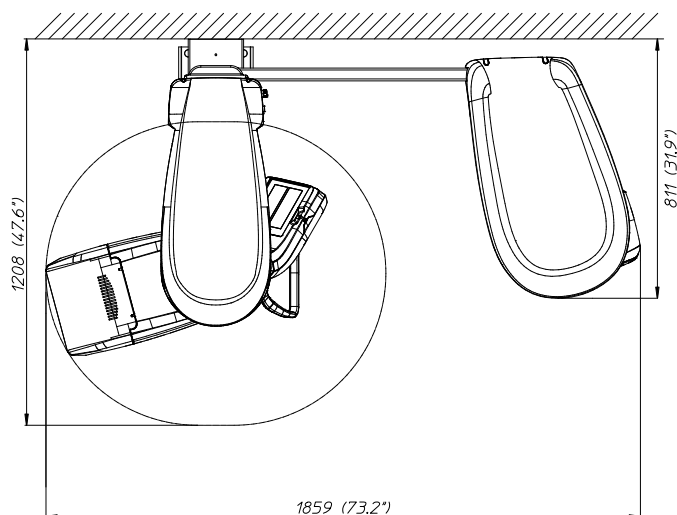

	I-Max PRO (2D)	I-Max Ceph PRO (2D)	I-Max 3D PRO	I-Max 3D Ceph PRO
<b>Category</b>	IIb / CE0051			
<b>Power supply</b>	110-120 V, 220-240 V à 50/60Hz			
<b>Anode voltage</b>	from 60 to 70 kV	from 60 to 86 kV		
<b>Anode current</b>	from 2 to 7,1 mA	from 2 to 12,5 mA		
<b>Total weight</b>	62 kg	118 kg	67 kg	123 kg
<b>Inherent filtration</b>	2 mm Al eq. @ 70kVp	> 2,5 mm Al. eq@ 86kVp		
<b>HF generator</b>	Constant potential (DC)			
<b>X-Ray focal spot</b>	0,5 mm EN 60336			
<b>Connection</b>	LAN, Ethernet			
<b>Voxel</b>	N/A		72µm (min. cross-section depth)	

	I-Max PRO (2D)	I-Max Ceph PRO (2D)	I-Max 3D PRO	I-Max 3D Ceph PRO
<b>2D panoramic</b>	■	■	■	■
<b>3D Cone Beam</b>			■	■
<b>Cephalometry</b>		■		■
<b>FOV</b>			12x10* / 9x9 / 9x5 / 5x5 cm	
<b>Programmes</b>	24 2D programmes	24 2D programmes 9 ceph programmes	18 3D programmes 24 2D programmes	18 3D programmes 24 2D programmes 9 ceph programmes
<b>Mounting</b>	Wall	Floor + wall	Wall	Floor + wall
<b>Guarantee</b>	2 years (optional 5 year** guarantee)			
<b>Installation options</b>	• Floor base plate • Wall column	• Floor base plate	• Floor base plate • Wall column	• Floor base plate

\*Optional

\*\*Guarantee valid for sensor and generator

# DIGITAL WORKFLOW OWANDY RADIOLOGY

A COMPREHENSIVE RANGE TO MEET ALL YOUR REQUIREMENTS

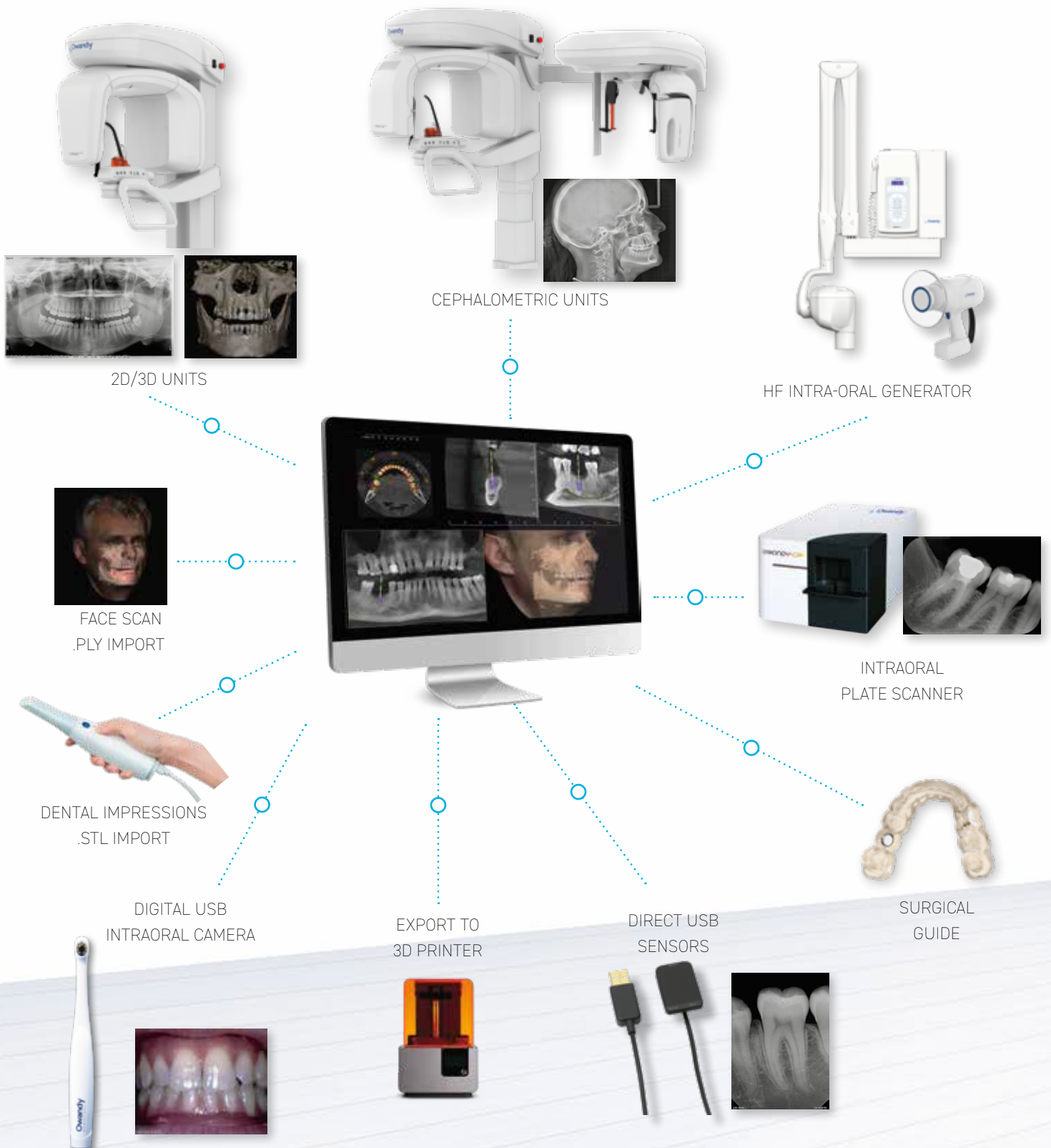

BR\_IMAX\_PRO\_EN\_Rev00

